

FnIO G – Series :

GT-3804

GT-3804 (4 Channels, TC/mV INPUT)

Specification

Table of Contents

[Table of Contents.....2](#)

[History.....3](#)

[1.ENVIRONMENT SPECIFICATION.....4](#)

[2.GT-3804 \(4 CHANNELS THERMOCOUPLE/MV INPUT\).....5](#)

[2.1.GT-3804 Specification.....5](#)

[2.2.GT-3804 Wiring Diagram.....7](#)

[2.3.GT-3804 LED Indicator.....8](#)

[2.3.1.LED Indicator.....8](#)

[2.3.2.Channel Status LED8](#)

[2.4.Mapping data into the image table.....9](#)

[2.5.Configuration Parameter – 8byte.....10](#)

[2.6.Data Value.....11](#)

Specification

History

REV.	PAGES	REMARKS	DATE	Editor
Preliminary		Preliminary	Dec 04, 2015	Jun, seok hyun
1,01	5	C/D Type accuracy is added	May 09, 2016	Hong, jin hyun
1,02	6	Power dissipation is revised to 130mA	June 01, 2016	Hong, jin hyun
1,03	4	Product cert : CE,UL UL Temperature is added	June 03, 2016	Hong, jin hyun
1,04	5	Conversion time is revised.	Oct 12, 2016	Hong, jin hyun
1,05	5	External Cold Junction Accuracy is added	Feb 13, 2017	Hong, Jin Hyun
1,06		Typo error is revised.	July 18, 2017	Hong, Jin Hyun
1,07	10	New feature added	Jan 31, 2020	Kim,Hong Seok
1.08		Release	Apr 21, 2020	Seokhyun, Jun

Specification

1. ENVIRONMENT SPECIFICATION

Environmental specification	
Operation Temperature	-40°C to 70°C
UL Temperature	-20°C to 60°C
Storage Temperature	-40°C to 85°C
Relative Humidity	5% to 95% Non-condensing
Operating Altitude	2,000m
Mounting	DIN Rail
General specification	
Shock Operating	IEC 60068-2-27 : 2008 / 15g, 11ms
Vibration Resistance	Based on IEC 60068-2-6 DNVGL-CG-0039 : Vibration Class B, 4g
Industrial Emissions	EN61000-6-4/All : 2011
Industrial Immunity	EN61000-6-2 : 2005
Installation Position	Vertical and horizontal installation is available
Product Certifications	CE, UL, FCC

2. GT-3804 (4 CHANNELS THERMOCOUPLE/MV INPUT)

2.1. GT-3804 Specification

Items	Specification																																																
Input Specification																																																	
Inputs per module	4 Channels																																																
Indicators(Logic side)	4 Green Input status , 1 Green Input CJ status																																																
Sensor Types	Thermal Couple Input Range <table border="1"> <thead> <tr> <th>Type</th> <th>Maximum Input Range</th> <th>Recommended Input Range</th> </tr> </thead> <tbody> <tr> <td>K</td> <td>-270 ~ 1372°C</td> <td>-200 ~ 1200°C</td> </tr> <tr> <td>J</td> <td>-210 ~ 1200°C</td> <td>-40 ~ 1100°C</td> </tr> <tr> <td>T</td> <td>-270 ~ 400°C</td> <td>-200 ~ 350°C</td> </tr> <tr> <td>B</td> <td>30 ~ 1820°C</td> <td>600 ~ 1700°C</td> </tr> <tr> <td>R</td> <td>-50~1768°C</td> <td>0 ~ 1600°C</td> </tr> <tr> <td>S</td> <td>-50 ~ 1768°C</td> <td>0 ~ 1600°C</td> </tr> <tr> <td>E</td> <td>-270 ~ 1000°C</td> <td>-200 ~ 800°C</td> </tr> <tr> <td>N</td> <td>-270 ~ 1300°C</td> <td>-200 ~ 1250°C</td> </tr> <tr> <td>L</td> <td>-200 ~ 900°C</td> <td>-100 ~ 850°C</td> </tr> <tr> <td>U</td> <td>-200 ~ 600°C</td> <td>-100 ~ 550°C</td> </tr> <tr> <td>C</td> <td>0 ~ 2310°C</td> <td>100 ~ 2100°C</td> </tr> <tr> <td>D</td> <td>0 ~ 2490°C</td> <td>100 ~ 2200°C</td> </tr> <tr> <td>10uV Input</td> <td colspan="2">-81.0 ~ 81.0mV, 10uV/ 1 Count</td> </tr> <tr> <td>1uV Input</td> <td colspan="2">-32.7 ~ 32.7mV, 1uV/ 1 Count</td> </tr> <tr> <td>2uV Input</td> <td colspan="2">-65.5 ~ 65.5mV, 2uV/ 1 Count</td> </tr> </tbody> </table>	Type	Maximum Input Range	Recommended Input Range	K	-270 ~ 1372°C	-200 ~ 1200°C	J	-210 ~ 1200°C	-40 ~ 1100°C	T	-270 ~ 400°C	-200 ~ 350°C	B	30 ~ 1820°C	600 ~ 1700°C	R	-50~1768°C	0 ~ 1600°C	S	-50 ~ 1768°C	0 ~ 1600°C	E	-270 ~ 1000°C	-200 ~ 800°C	N	-270 ~ 1300°C	-200 ~ 1250°C	L	-200 ~ 900°C	-100 ~ 850°C	U	-200 ~ 600°C	-100 ~ 550°C	C	0 ~ 2310°C	100 ~ 2100°C	D	0 ~ 2490°C	100 ~ 2200°C	10uV Input	-81.0 ~ 81.0mV, 10uV/ 1 Count		1uV Input	-32.7 ~ 32.7mV, 1uV/ 1 Count		2uV Input	-65.5 ~ 65.5mV, 2uV/ 1 Count	
Type	Maximum Input Range	Recommended Input Range																																															
K	-270 ~ 1372°C	-200 ~ 1200°C																																															
J	-210 ~ 1200°C	-40 ~ 1100°C																																															
T	-270 ~ 400°C	-200 ~ 350°C																																															
B	30 ~ 1820°C	600 ~ 1700°C																																															
R	-50~1768°C	0 ~ 1600°C																																															
S	-50 ~ 1768°C	0 ~ 1600°C																																															
E	-270 ~ 1000°C	-200 ~ 800°C																																															
N	-270 ~ 1300°C	-200 ~ 1250°C																																															
L	-200 ~ 900°C	-100 ~ 850°C																																															
U	-200 ~ 600°C	-100 ~ 550°C																																															
C	0 ~ 2310°C	100 ~ 2100°C																																															
D	0 ~ 2490°C	100 ~ 2200°C																																															
10uV Input	-81.0 ~ 81.0mV, 10uV/ 1 Count																																																
1uV Input	-32.7 ~ 32.7mV, 1uV/ 1 Count																																																
2uV Input	-65.5 ~ 65.5mV, 2uV/ 1 Count																																																
Module Accuracy (Need 20 minute preheating to get enhanced accuracy.)	Recommend Input Range <ul style="list-style-type: none"> • ±0.1% Recommended Scale @ 25°C ambient • ±0.3% Recommended Scale @ -40°C~70°C C/D type Recommend Input Range <ul style="list-style-type: none"> • ±0.3% Recommended Scale @ -40°C~70°C External Cold Junction(PT100) <ul style="list-style-type: none"> • ±2°C Recommended Scale @ -40°C~70°C 																																																
Connection Method	2-Wire																																																
Conversion Time	Average Conversion time < 30ms																																																
Data Format	16bits Integer (2' complement)																																																
Cold junction temperature	Internal - TMP275AIDGKR : -40°C~125°C External																																																

Specification

	- PT100 : -45°C~95°C
Calibration	Not Required
Diagnostic	Sensor open or range over, then conversion data = 0x8000(-32768) * Connected External CJ : CJ LED On. Not Connected External CJ : CJ LED Off.
General specification	
Power dissipation	Max. 130mA @ 5Vdc
Isolation	I/O to Logic : Isolation Field power : Not Connected
UL Field Power	Supply Voltage : 24Vdc nominal, Class 2
Field Power	Not used, Field power bypass to next expansion module
Wiring	I/O Cable Max. 2.0mm ² (AWG 14)
Torque	0.8Nm(7lb-in)
Weight	60g
Module Size	12mm x 99mm x 70mm
Environment Condition	Refer to 'Environment Specification'

* To increase precision of measurement, the connection between GT-3804 and compensation reference sensor is recommended using by terminal block.

2.2. GT-3804 Wiring Diagram

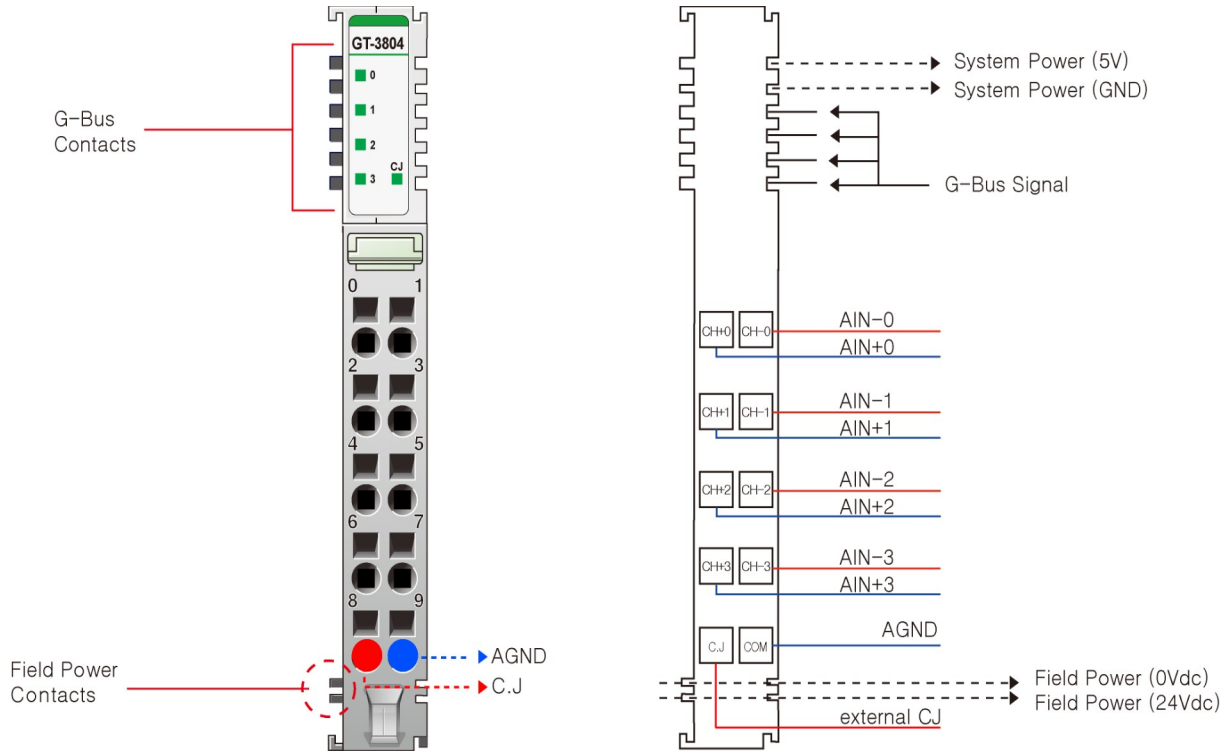
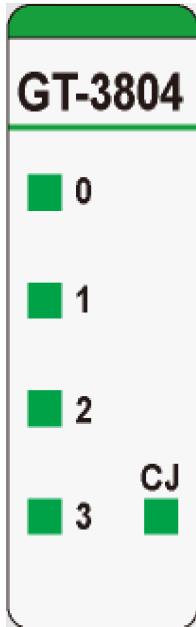

Figure 1. Customer Wiring to Mounting Base

Pin No.	Signal Description	Signal Description	Pin No.
0	TC Channel 0+	TC Channel 0-	1
2	TC Channel 1+	TC Channel 1-	3
4	TC Channel 2+	TC Channel 2-	5
6	TC Channel 3+	TC Channel 3-	7
8	CJ	AGND	9

2.3. GT-3804 LED Indicator

2.3.1. LED Indicator



LED No.	LED Function / Description	LED Color
0	INPUT Channel 0	Green
1	INPUT Channel 1	Green
2	INPUT Channel 2	Green
3	INPUT Channel 3	Green
CJ	INPUT Channel CJ	Green

2.3.2. Channel Status LED

Status	LED	To indicate
No Signal, Normal Operation	Channel LED Off, CJ LED Off	Input Sensor Open or Input Range Over Normal Operation
On Signal Normal Operation	Channel LED On, CJ LED Off	Sensor Connected and Input Range Valid Normal Operation
On Signal Normal Operation Connected External CJC	Channel LED On, CJ LED On	Sensor Connected and Input Range Valid Normal Operation, External CJ enable

2.4. Mapping data into the image table

- **Input Module Data**

	Analog Input Ch0
	Analog Input Ch1
	Analog Input Ch2
	Analog Input Ch3

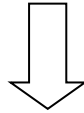

- **Input Image Value**

Bit No	Bit7	Bit6	Bit5	Bit4	Bit3	Bit2	Bit1	Bit0
Byte 0	Analog Input Ch0 Low byte							
Byte 1	Analog Input Ch0 High byte							
Byte 2	Analog Input Ch1 Low byte							
Byte 3	Analog Input Ch1 High byte							
Byte 4	Analog Input Ch2 Low byte							
Byte 5	Analog Input Ch2 High byte							
Byte 6	Analog Input Ch3 Low byte							
Byte 7	Analog Input Ch3 High byte							

- If the input of channel is open or over-ranged, its conversion data will be 0x8000(-32678)

2.5. Configuration Parameter – 8byte

Byte	Decimal Bit	Description	Default Value
0	00-07	The selection Sensor Type =00h: Type K, 0.1°C/count =01h: Type J, 0.1°C/count =02h: Type T, 0.1°C/count =03h: Type B, 0.1°C/count =04h: Type R, 0.1°C/count =05h: Type S, 0.1°C/count =06h: Type E, 0.1°C/count =07h: Type N, 0.1°C/count =08h: Type L, 0.1°C/count =09h: Type U, 0.1°C/count =0Ah: Type C, 0.1°C/count =0Bh: Type D, 0.1°C/count =80h: 10uV Input, -81.0~81.0mV, 10uV / 1count =81h: 1uV Input, -32.7~32.7mV, 1uV / 1count =82h: 2uV Input, -65.5~65.5mV, 2uV / 1count =Others: Reserved	00 : Type K
1	00	Temperature Type 0: Celsius(°C), 1: Fahrenheit(°F)	00 : Celsius(°C) Cold Junction Compensation 0.1°C Normal Filter
	01*	Cold Junction Compensation 0: Cold Junction Compensation 1: Disable Cold Junction Compensation	
	02	Data Resolution 0: 0.1°C, °F/bit, 1: 1°C, °F/bit	
	03	Reserved	
	04	Filter Type 0: Normal Filter, 1: Enhanced Filter	
	05-06	SW Filter 0: Normal Filter(Filter Time = 20) 1: *Fast Filter(Filter Time = 3) 2: Enhanced Filter(Filter Time = 40) 3: More Enhanced Filter(Filter Time = 80)	
	07	Reserved	
2	00-07	Internal Cold Junction[1] Offset Data Low Byte	0000
3	00-07	Internal Cold Junction[1] Offset Data High Byte	
4	00-07	Internal Cold Junction[2] Offset Data Low Byte	0000
5	00-07	Internal Cold Junction[2] Offset Data High Byte	
6	00-07	External Cold Junction Offset Data Low Byte	0000
7	00-07	External Cold Junction Offset Data High Byte	

- Unit of Cold Junction Temperature is 0.1°C/°F. Value 254 means 25.4°C or 25.4°F

- *0: Compensation Cold Junction Temperature = Cold Junction Temperature – Cold Junction Temperature Offset

- *1: Compensation Cold Junction Temperature = Cold Junction Temperature Offset

- *If you set a fast filter, the specification accuracy may not be met.

Specification

2.6. Data Value

Thermocouple Input Range		
Type	Maximum Input Range	Recommended Input Range
Type K	-270 ~ 1372 °C	-200 ~ 1200 °C
Type J	-210 ~ 1200 °C	-40 ~ 1100 °C
Type T	-270 ~ 400 °C	-200 ~ 350 °C
Type B	30 ~ 1820 °C	600 ~ 1700 °C
Type R	-50 ~ 1768 °C	0 ~ 1600 °C
Type S	-50 ~ 1768 °C	0 ~ 1600 °C
Type E	-270 ~ 1000 °C	-200 ~ 800 °C
Type N	-270 ~ 1300 °C	-200 ~ 1250 °C
Type L	-200 ~ 900 °C	-100 ~ 850 °C
Type U	-200 ~ 600 °C	-100 ~ 550 °C
Type C	0 ~ 2310 °C	100 ~ 2100 °C
Type D	0 ~ 2490 °C	100 ~ 2200 °C
10uV	-81.0 ~ 81.0mV, 10uV/ 1 Count	
1uV	-32.7 ~ 32.7mV, 1uV/ 1 Count	
2uV	-65.5 ~ 65.5mV, 2uV/ 1 Count	

- °F = 1.8°C+32